

TOP VIEW

WITHOUT DIE

BALL VIEW

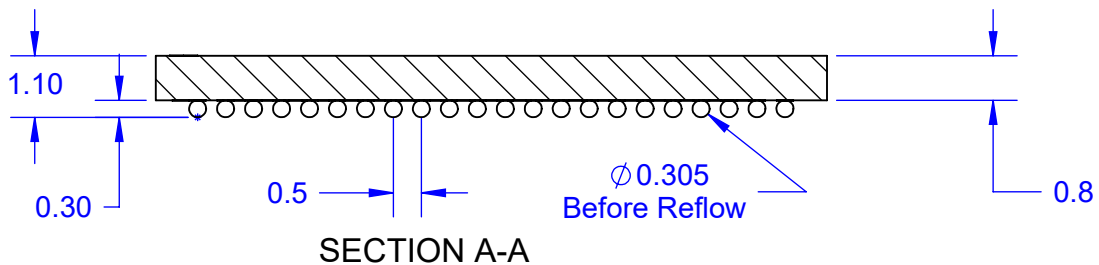
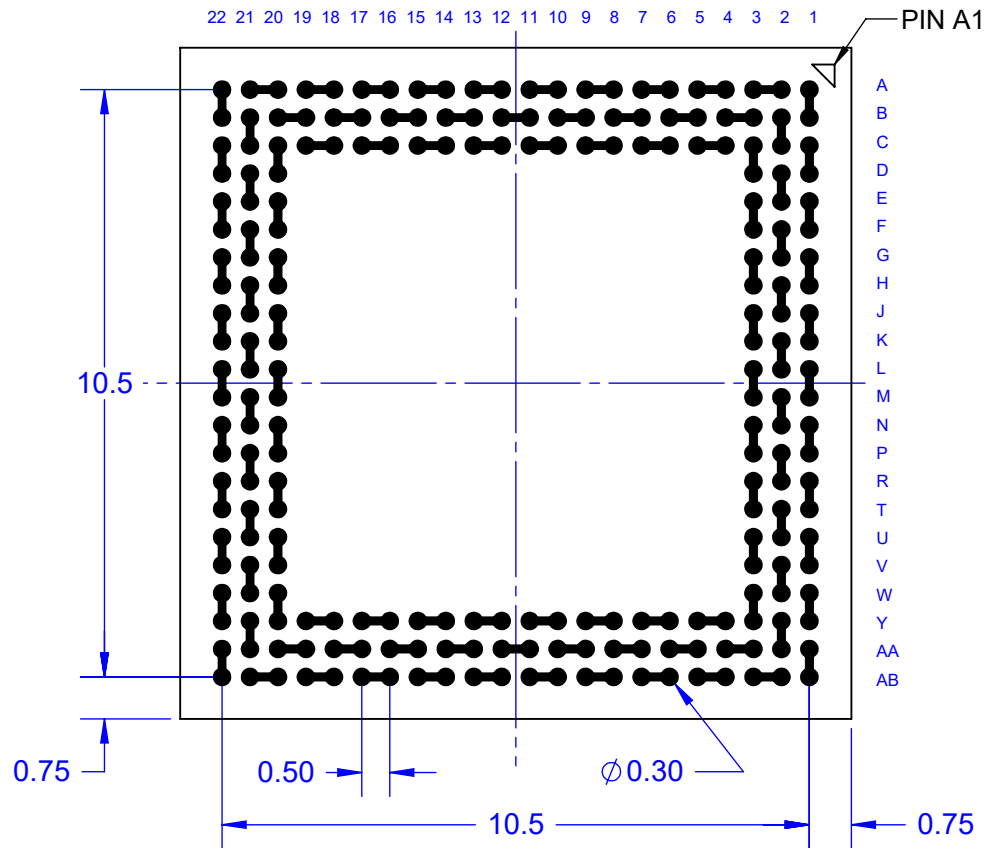
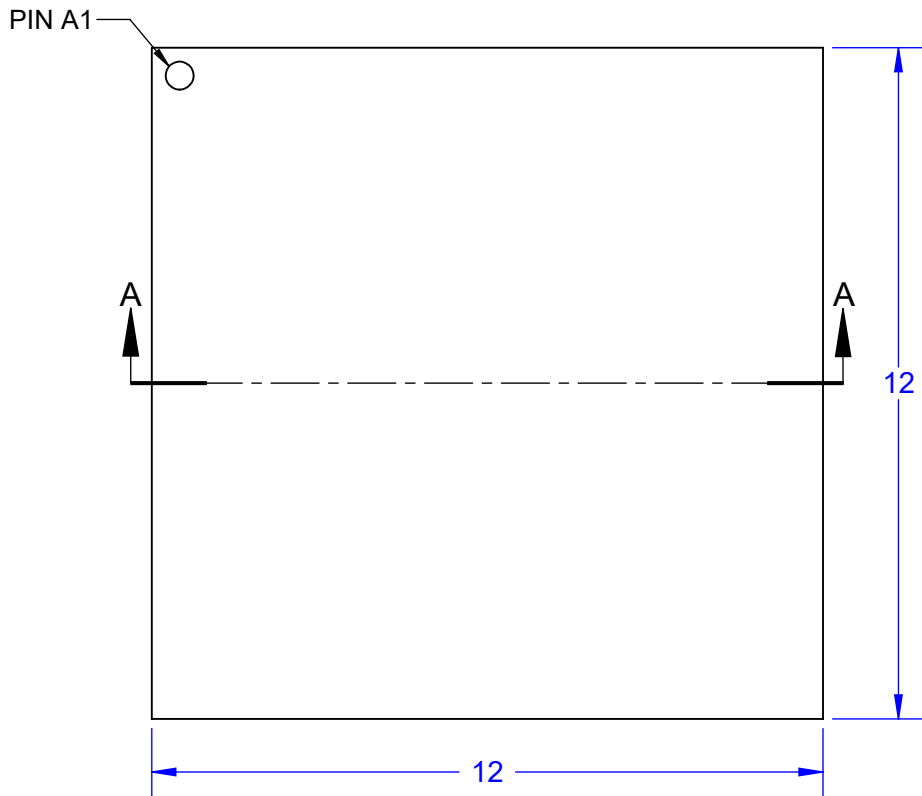

Notes: (Unless Otherwise Specified).

- 1) ALL DIMENSIONS ARE IN MM.
- 2) SOLDER BALL ALLOY: SEE PART NUMBER TABLE.
- 3) BALL DIAMETER (BEFORE REFLOW): 0.30mm.
- 4) SOLDER MASK DEFINED PAD OPENING: 0.28mm (11 MIL).
- 5) PAD Cu DIAMETER: 0.355mm (14 MIL).
- 6) SUBSTRATE MATERIAL: BT.
- 7) DUMMY DIE IS OPTIONAL.
- 8) DAISY CHAIN PATTERN (SEE PAGE 2).
- 9) MSL-3 RECOMMENDED BAKING 24 HOURS @ 125°C TO REMOVE MOISTURE PRIOR SOLDERING TO PC BOARD.

PART NUMBER TABLE				
PART NUMBER	BALL ALLOY	Pb-Free	RoHS	Si DIE
LBGA228T.5C-DC222B	Sn96.5/Ag3.0/Cu0.5	YES	YES	NO
LBGA228T.5-DC222B	Sn63/Pb37	NO	NO	NO

APPROVALS	DATE	TopLine®			
DRAWN T.Au	7/25/2022				
ENG M. Hart	7/25/2022	TITLE LBGA228T.5-DC222B DAISY CHAIN DUMMY			
MFG		SCALE 7.5:1	SIZE A	DRAWING NO. 552220	REV B
QA		DO NOT SCALE DRAWING			SHEET 1 OF 5
CUST					
REVISED					

TOP VIEW

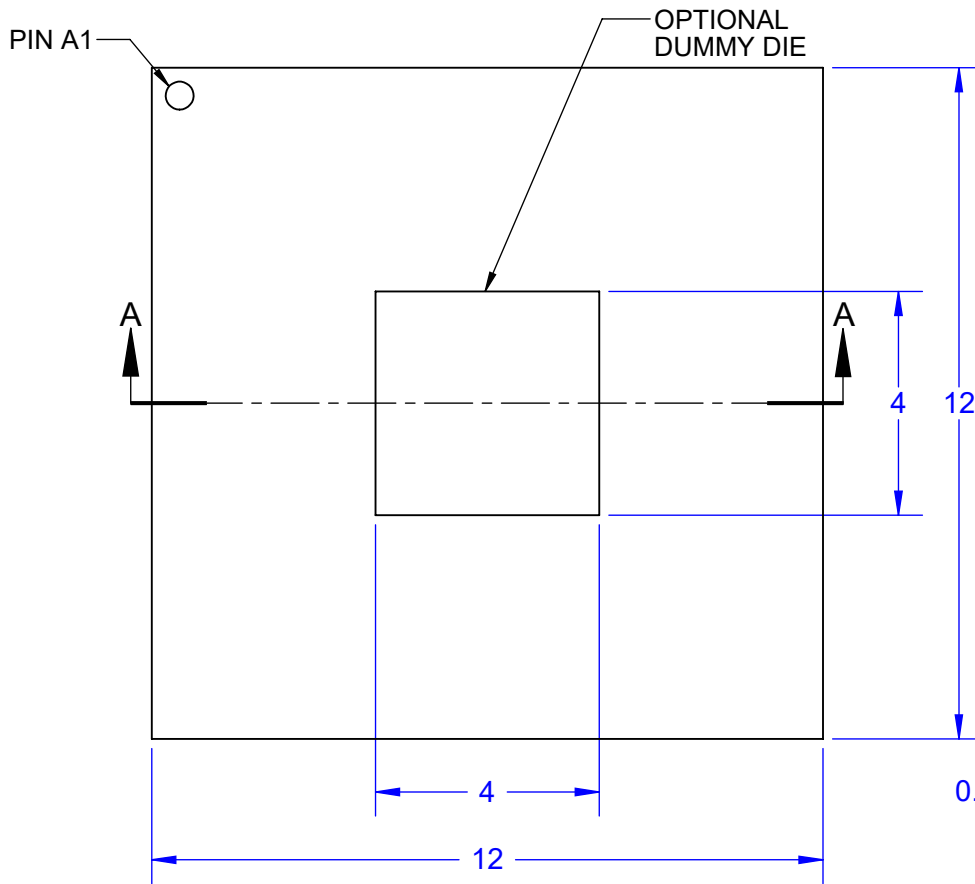

BALL VIEW

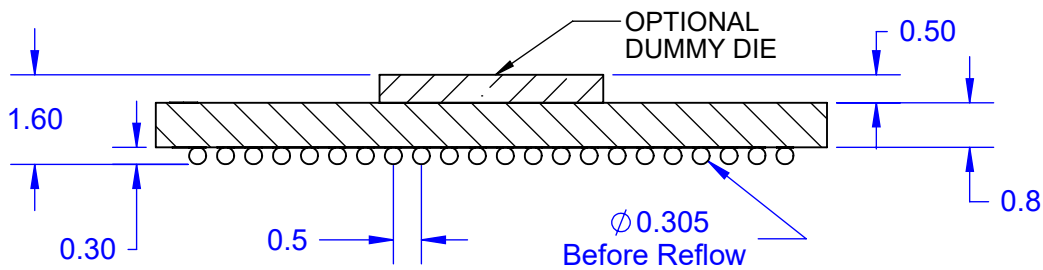
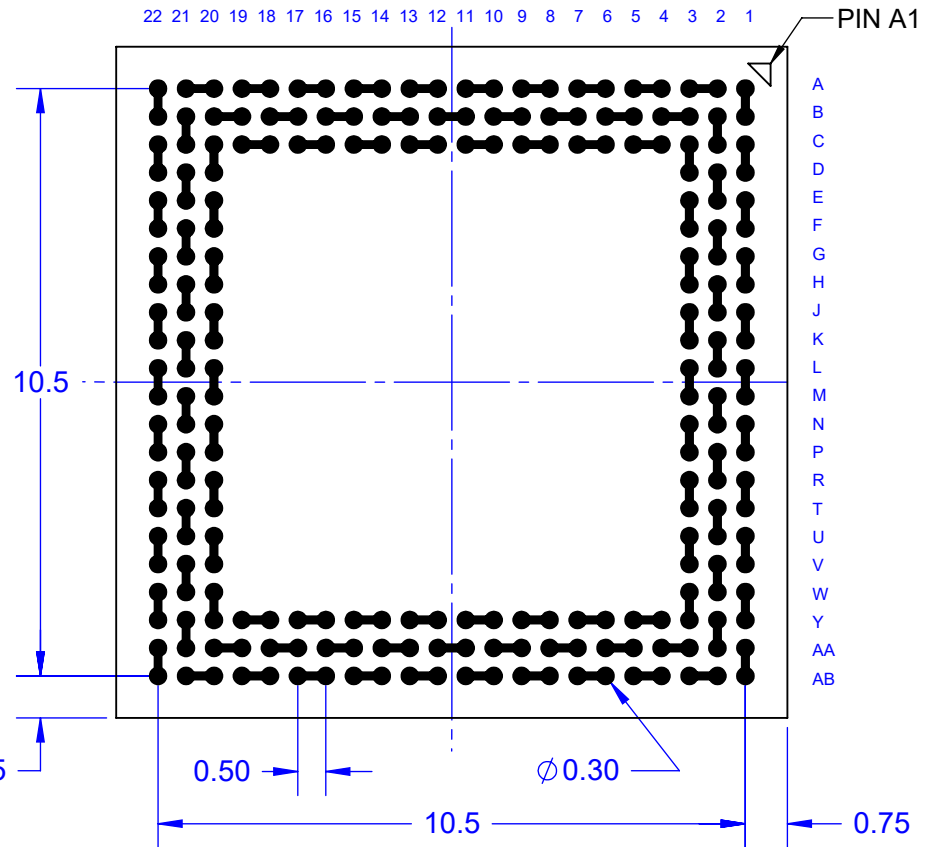

SECTION A-A

Notes: (Unless Otherwise Specified).

- 1) ALL DIMENSIONS ARE IN MM.
- 2) SOLDER BALL ALLOY: SEE PART NUMBER TABLE.
- 3) BALL DIAMETER (BEFORE REFLOW): 0.30mm.
- 4) SOLDER MASK DEFINED PAD OPENING: 0.28mm (11 MIL).
- 5) PAD Cu DIAMETER: 0.355mm (14 MIL).
- 6) SUBSTRATE MATERIAL: BT.
- 7) DUMMY DIE IS OPTIONAL.
- 8) DAISY CHAIN PATTERN (SEE PAGE 2).
- 9) MSL-3 RECOMMENDED BAKING 24 HOURS @ 125°C TO REMOVE MOISTURE PRIOR SOLDERING TO PC BOARD.

PART NUMBER TABLE				
PART NUMBER	BALL ALLOY	Pb-Free	RoHS	Si DIE
LBGA228T.5C-DC222BD	Sn96.5/Ag3.0/Cu0.5	YES	YES	YES
LBGA228T.5-DC222BD	Sn63/Pb37	NO	NO	YES

APPROVALS	DATE	TopLine®			
DRAWN T.Au	7/25/2022				
ENG M. Hart	7/25/2022	TITLE		LBGA228T.5-DC222B DAISY CHAIN DUMMY	
MFG		SCALE	SIZE	DRAWING NO.	REV
QA		7.5:1	A	552220	B
CUST		DO NOT SCALE DRAWING			SHEET 2 OF 5
REVISED					

BALL VIEW

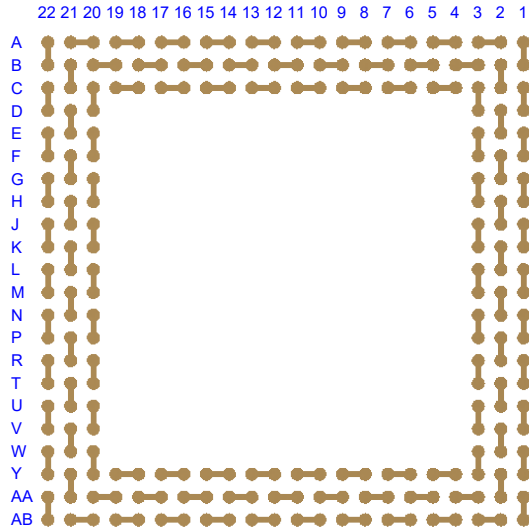

BOTTOM SIDE (TOP X-RAY VIEW)

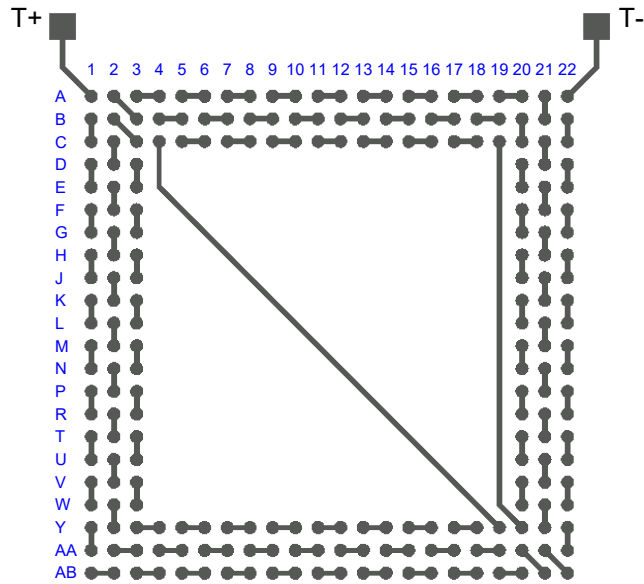
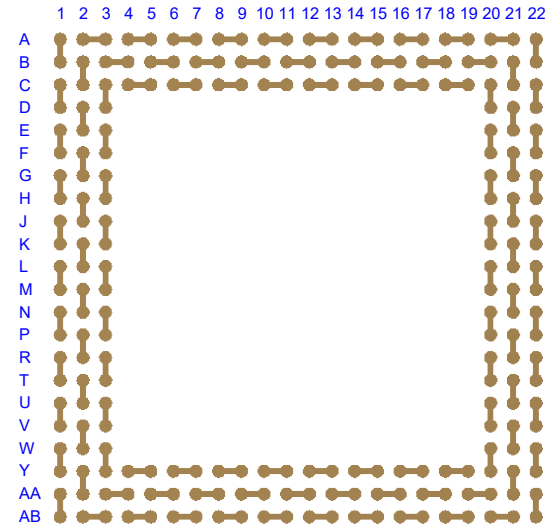

TEST VEHICLE BOARD

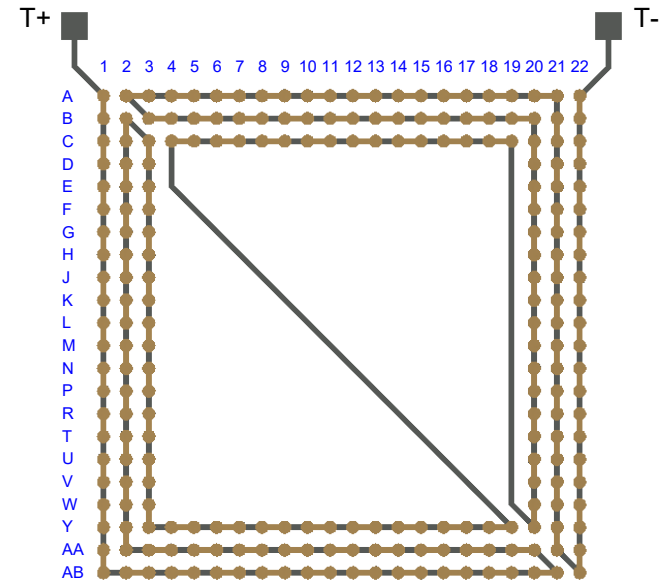

AFTER MOUNTING

Notes:

- 1) PCB BOARD DIMENSIONS ARE PRESENTED ONLY AS A GUIDELINE. DESIGNERS SHOULD USE THEIR OWN EXPERIENCE WHEN DESIGNING PCB.
- 2) PCB Cu BALL PAD DIAMETER 0.355mm (14 MIL).
- 3) PCB DAISY CHAIN TRACING LINE WIDTH 0.127mm (5 MIL).
- 4) SMD (SOLDER MASK DEFINED) PAD OPENING: 0.28mm (11 MIL).

TopLine®			
TITLE		LBGA228T.5-DC222B DAISY CHAIN DUMMY	
SCALE	SIZE	DRAWING NO.	REV
6:1	A	552220	B
DO NOT SCALE DRAWING			SHEET 3 OF 5

MODEL (WITHOUT DIE)

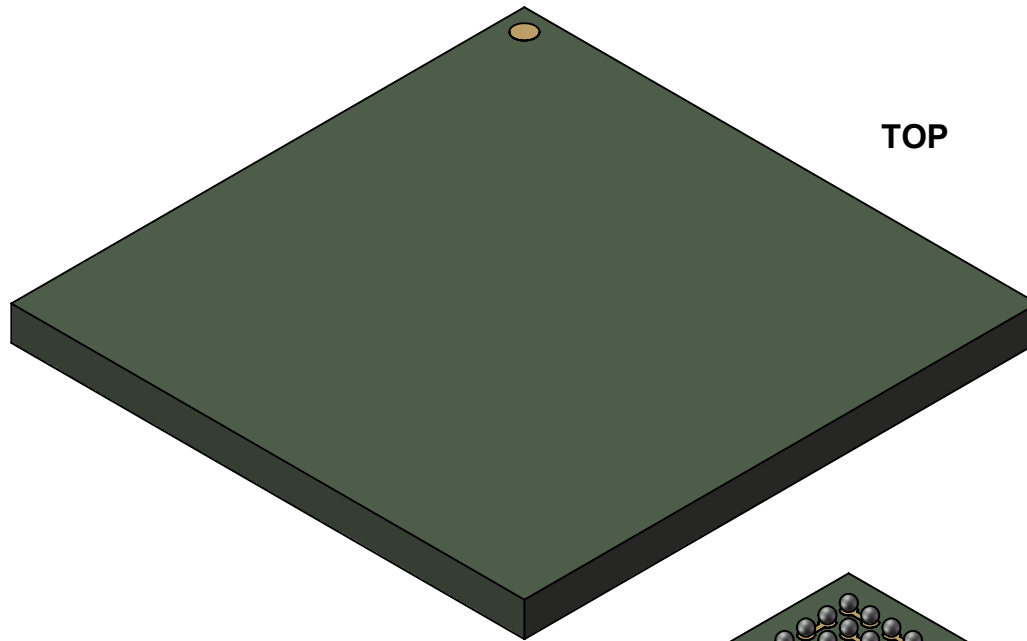

TOP

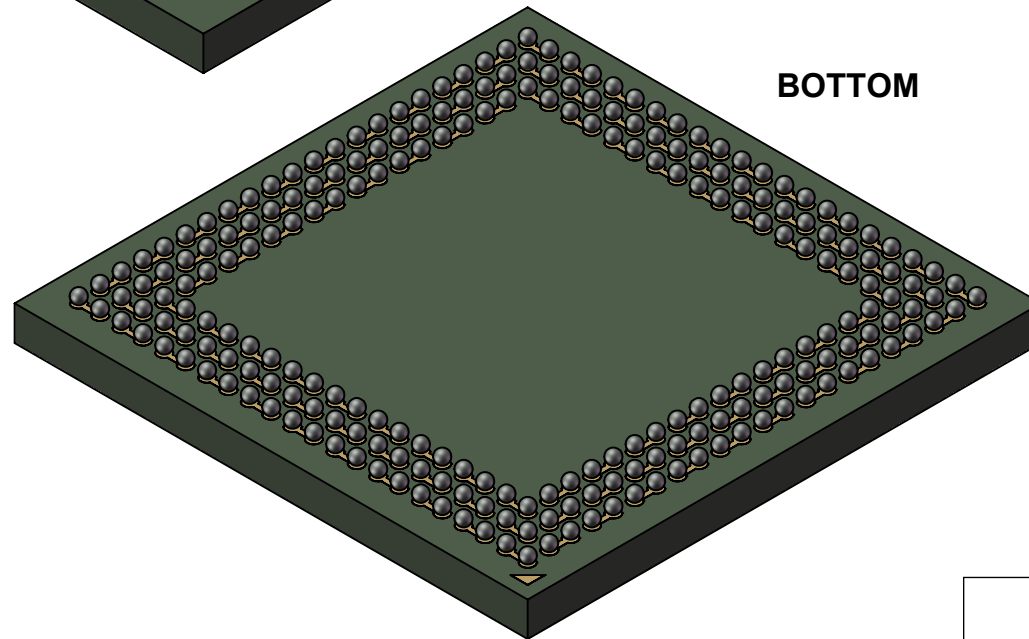

BOTTOM

TopLine[®]

TITLE LBGA228T.5-DC222B
DAISY CHAIN DUMMY

SCALE 6:1	SIZE A	DRAWING NO. 552220	REV B
--------------	-----------	-----------------------	----------

DO NOT SCALE DRAWING

SHEET 4 OF 5

MODEL (WITH DIE)

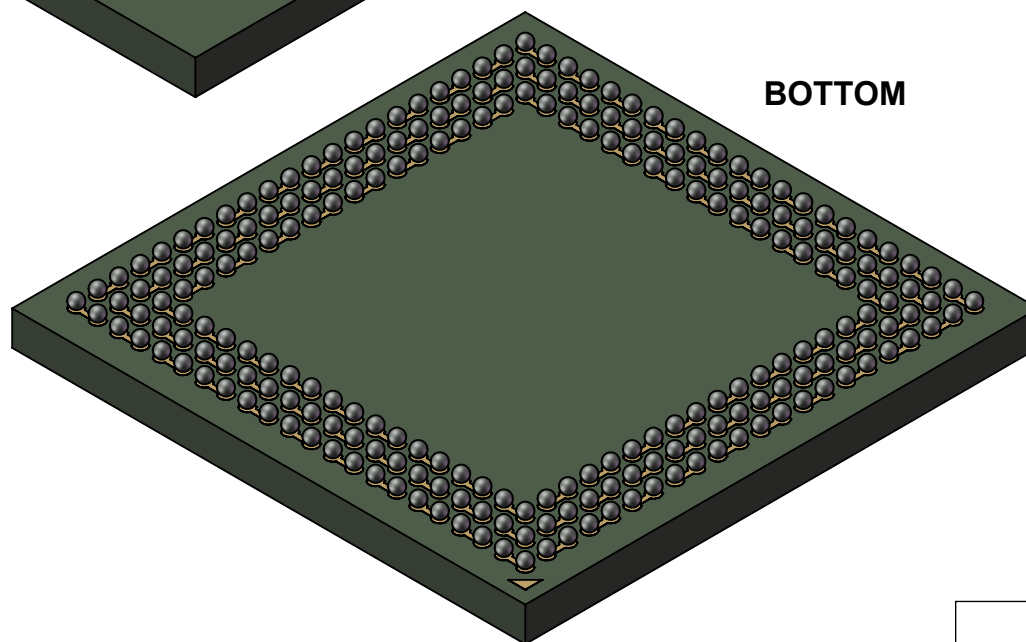
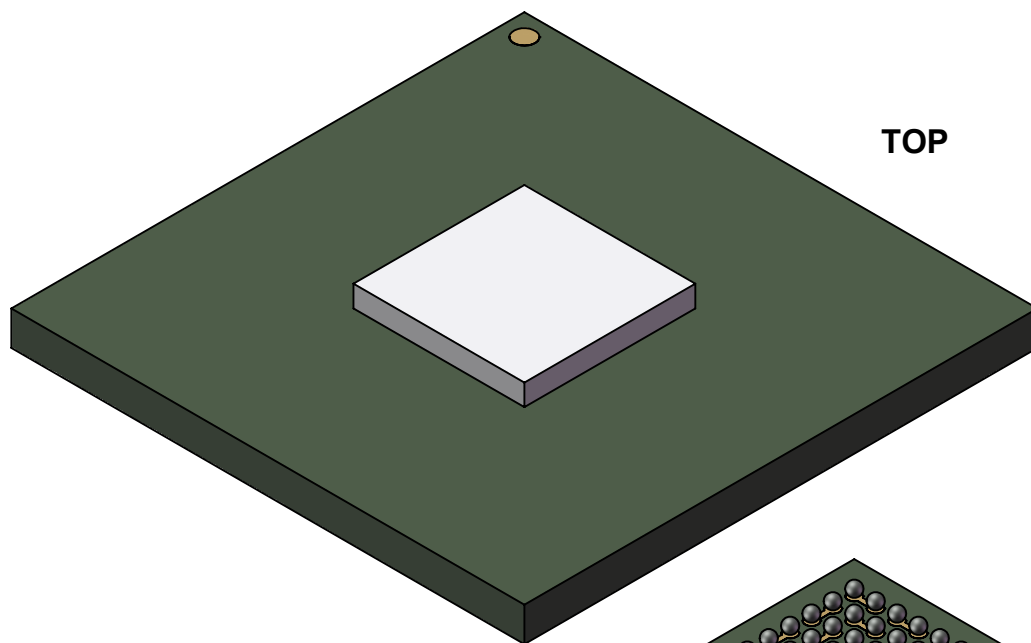

TopLine[®]

TITLE LBGA228T.5-DC222B
DAISY CHAIN DUMMY

SCALE 6:1	SIZE A	DRAWING NO. 552220	REV B
--------------	-----------	-----------------------	----------

DO NOT SCALE DRAWING

SHEET 5 OF 5